



COMFORTABLE LIVING

For almost 20 years Ravenheat have been at the forefront of design and production of high efficiency reliable combi boilers and we are proud of it.



Manufactured by Ravenheat to the highest quality standards, the RSF84E(T) and RSF100E(T) are simple to install and offer the installer/householder the comprehensive coverage required to meet the needs of the modern home.

Reliable and economical to run, these fully modulating boilers, exceed all the current standards for safety, efficiency and performance. Built to exacting ISO 9001 standards all boilers carry the European CE mark.



This high performance boiler will meet all the demands of modern living. Each appliance is 100% function tested, which benefits the installer and customer alike. Ravenheat's commitment to customer care is second to none.



HIDDEN ENGINEERING EXCELLENCE

With the RSF84E(T) and RSF100E(T) all the hot water you need is on tap day and night. The water is heated straight from the cold mains, so you don't have to wait for a storage tank to refill and heat up.

Fitting could not be easier. The RSF84E(T) & RSF100E(T) come pre-wired with 1 metre of cable and an electronic ignition system for even greater economy. The easy to understand control panel makes it extremely user friendly with a one push button timer for ease of heating control.

Our design team have gone to great lengths to develop our 7 day digital timer. Easy to set up and operate, the timer includes our unique cover which prevents accidental loss of programming or tampering, while allowing day to day flexibility.

Ravenheat's commitment to efficiency reduces harmful emissions. The Ravenheat RSF84E(T) & RSF100E(T) are totally room sealed appliances,

taking their combustion air to the outside, which also ensures maximum safety. Multi choice flueing systems include both a horizontal and a vertical twin flue system, for ease of installation in any application.

Ravenheat are the only manufacturer producing a re-usable Jig Fixing/Testing Facility which is proving to be extremely popular with Heating Engineers, Builders and Local Authorities.

Each Ravenheat appliance undergoes a rigorous testing and operating procedure before being carefully packed for maximum protection ready to leave our factory.

We operate a serial numbered guarantee card system of registration for users' convenience to easily identify the type of boiler.

Technical support for the installer is only a telephone call away for on or off site advice. We have an unrivaled speedy after sales service should this be necessary.

FLUE OPTIONS

Concentric Flue Duct

The boiler comes complete with a standard horizontal flue kit (1 metre long). If required, the flue may be extended up to 2.5 metres horizontally. A vertical flue is also available where a horizontal flue is not possible or desired and can run up to 4 metres vertically in length, by the use of flue extension pipes.

Eccentric Flue Duct

This boiler can be used with the eccentric flue system – enabling flueing up to 29 metres air intake/exhaust from the boiler. A special two way header can be fitted to the top of the appliance which guarantees a perfect connection between the boiler's sealed combustion chamber and the two pipes.

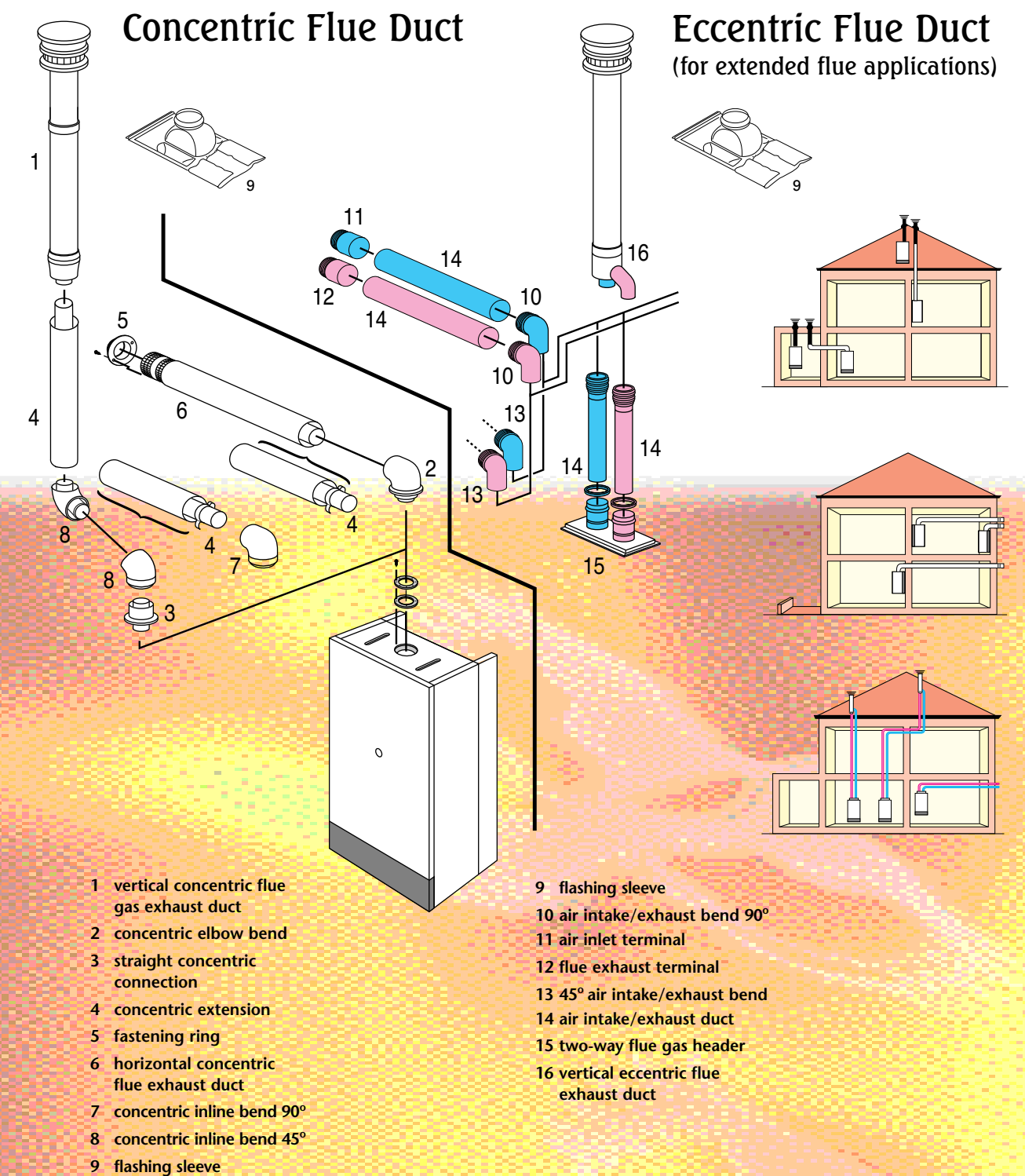



Style and
Elegance

Hot water is always delivered at a high flow rate, even if your mains pressure is low, this gives you the added benefits of exhilarating power showering without going to the expense of installing a pump or a power shower. Showering also uses far less water than taking a bath so the RSF84E(T) and RSF100E(T) are far more economical and help conserve water – a vital natural resource.

Boiler Efficiency – SEDBUK		
RSF 84E(T)	78.8%	BAND D
RSF 100E(T)	78.9%	BAND D
RSF 84E(T)LPG	81.0%	BAND D
RSF 100E(T)LPG	81.2%	BAND D

SUMMARY OF TECHNICAL BENEFITS

- High performance.
- Fully modulating heating and hot water boiler.
- High domestic hot water flow rate.
- 7 day digital timer as standard.
- Easy to install.
- User variable heating and hot water thermostats.
- Anti-cycle control enables the boiler to be fitted to any large or small heating system design.
- Energy saving soft light electronic ignition system.
- Multi level safety features.
- Manual re-set overheat cut-out.
- Neon safety check indicator.
- Central heating low water cut-off switch.
- 360° flue terminal option as standard.
- Vertical flue availability 4.0 metres.
- Built in frost stat facility.
- Jig fixing/testing facility for on site security.
- Available for natural gas or LPG.
- Built in variable head pump suitable for any type of central heating system.

		MODEL RSF84E(T)	MODEL RSF100E(T)
CENTRAL HEATING INPUT MAX-MIN		Btu/h kW	91,800 - 49,850 26.9 - 14.6
OUTPUT MAX-MIN ADJUSTABLE		Btu/h kW	83,900 - 39,250 24.6 - 11.5
DOMESTIC HOT WATER FLOW RATE RAISED		l/min	11.8 (2.60 Gal)
30°C		l/min	10.1 (2.22 Gal)
35°C			14.2 (3.12 Gal)
			12.2 (2.68 Gal)
DOMESTIC HOT WATER OUTPUT MAX-MIN		Btu/h kW	83,900-39,250 24.6-11.5
EXPANSION VESSEL		l	8
MAX CENTRAL HEATING TEMPERATURE		°C	85
CONNECTION HEATING FLOW & RETURN COMPRESSION		mm	22
GAS CONNECTION COMPRESSION		mm	15
DOMESTIC SUPPLY (COLD) COMPRESSION		mm	15
DOMESTIC SUPPLY (HOT) COPPER		mm	15
WEIGHT		Kg	46
FLUE SIZE		mm	100
ELECTRICAL MAINS SUPPLY			230V 50Hz
SEDBUK	NAT GAS	%	78.8 BAND D
	LPG	%	81.0 BAND D
			78.9 BAND D
			81.2 BAND D

- | | |
|---------------------------------------|---|
| 1 air pressure switch | 14 safety valve |
| 2 sealed combustion | 15 water gauge/thermostat |
| 3 heat exchanger | 16 circulation pump |
| 4 safety thermostat | 17 shunt valve |
| 5 DHW heat exchanger | 18 DHW priority pressure switch |
| 6 spark electrode | 19 burner |
| 7 modulating gas valve | 20 expansion vessel |
| 8 low water cut-off switch | 21 cut-off thermostat |
| 9 DHW thermostat control | 22 fan |
| 10 isolating valve | 23 automatic air vent |
| 11 central heating thermostat control | 24 concentric bend fitting |
| 12 isolating valve | 25 straight concentric fitting |
| 13 isolating valve | 26 two-way flue gas header (for eccentric exhaust connection) |

The company reserves the right to alter specifications at any time without notice.
Available in natural gas model or LPG.
Kitchens supplied by Sheraton Kitchens. Tel:01405 743322

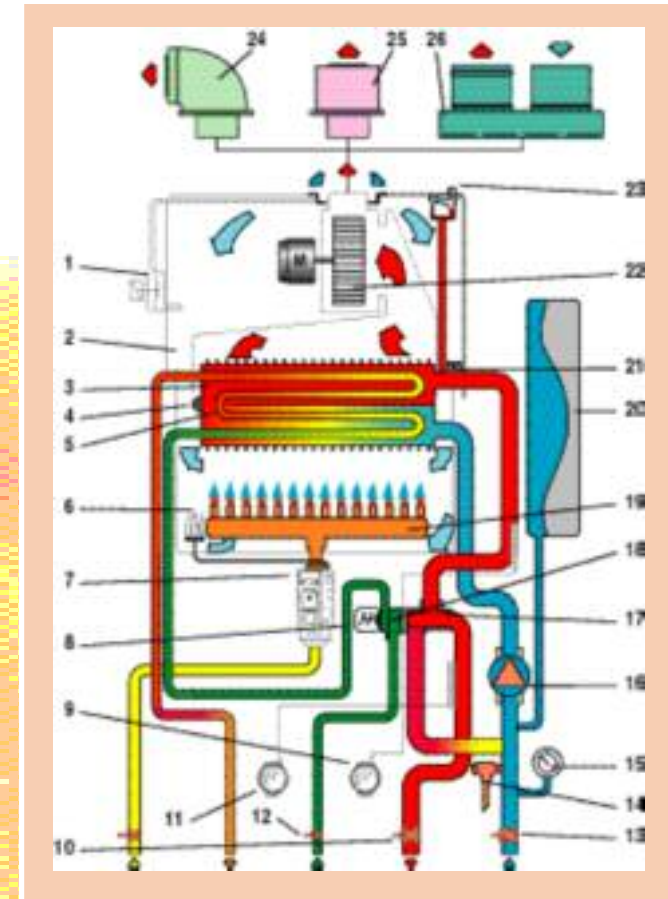
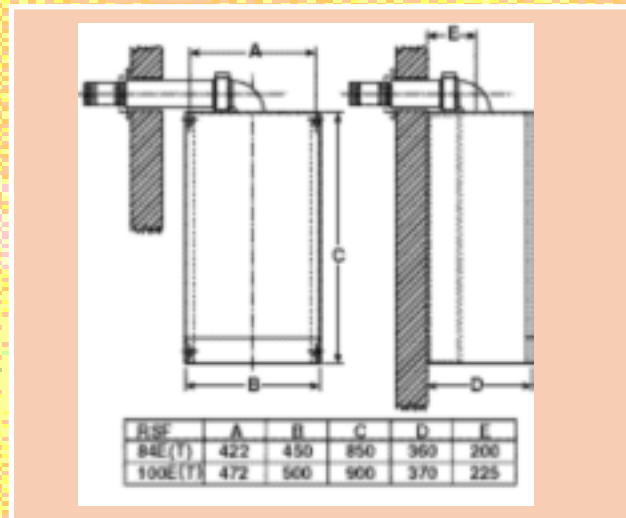

THE TOP model

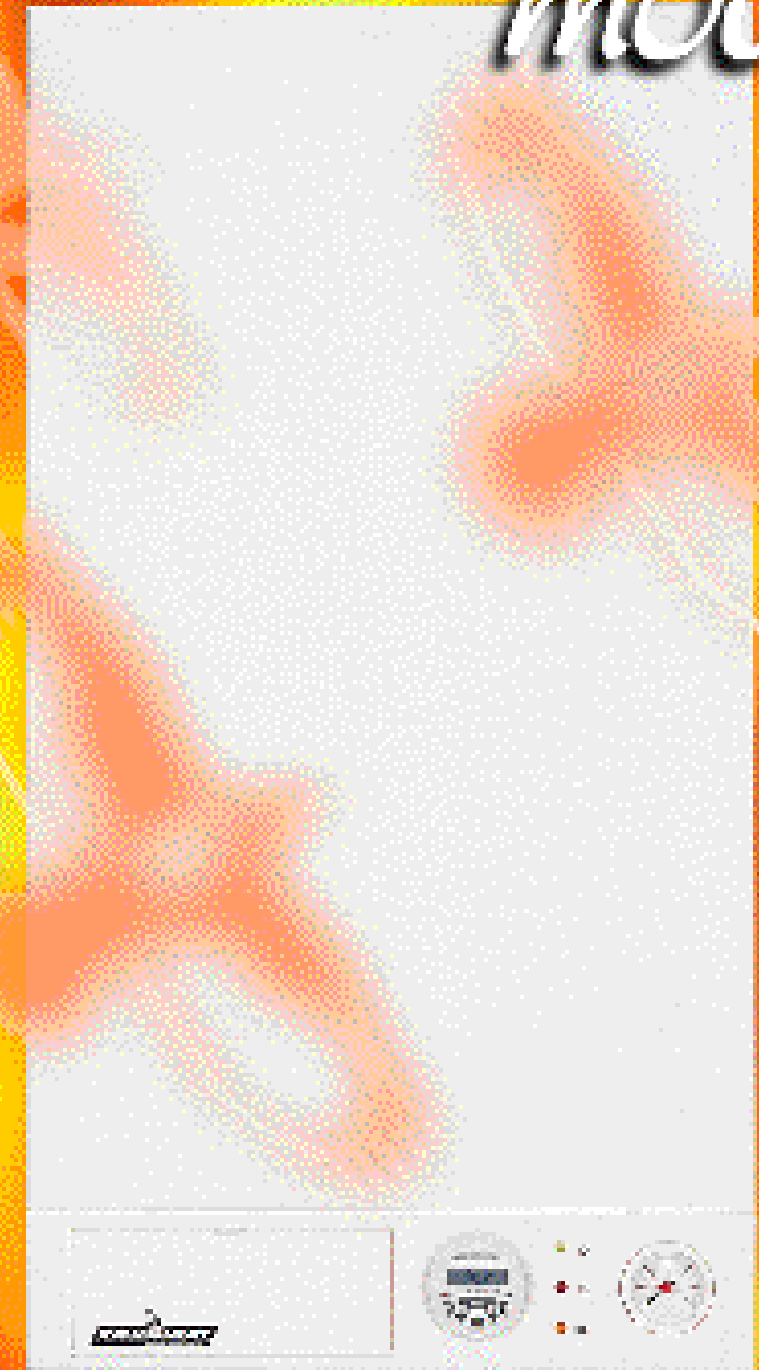

RSF84E(T) RSF100E(T)



Chartists Way, Morley, Leeds LS27 9ET. Telephone: 0113 252 7007. Fax: 0113 238 0229
Website: <http://www.ravenheat.co.uk> E-mail: sales@ravenheat.co.uk

